

1 2 3 4 5 6 7 8

A

B

C

D

E

F

G

H

A

B

C

D

E

F

G

H

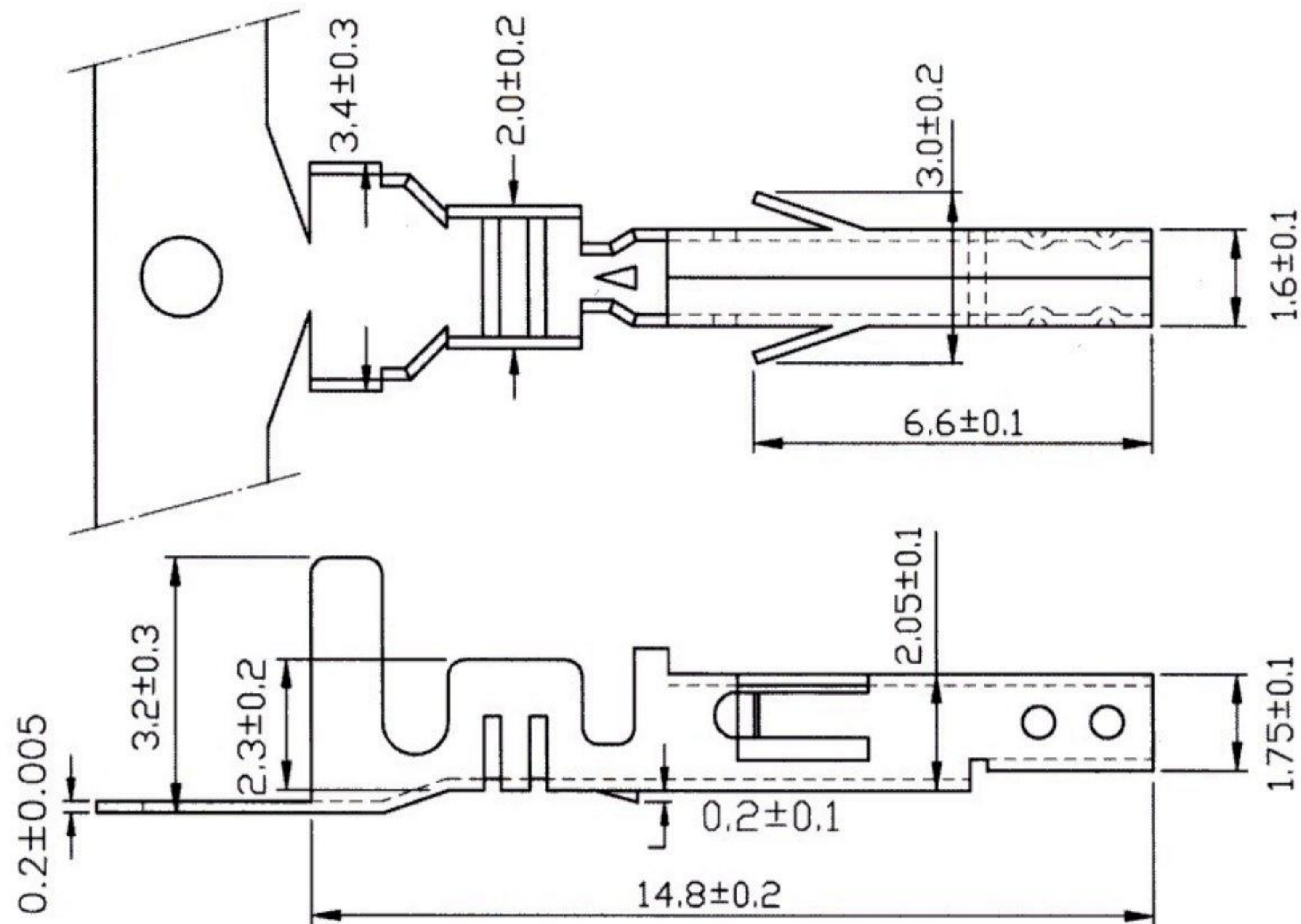

TOLERANCES UNLESS OTHERWISE SPECIFIED		±0.4	±0.5
	PARTITION	20-40	40 UP
	TYPE	±0.2	±0.3
	PARTITION	1-10	10-20

THICKNESS: 0.2mm
 MAT'L: BRASS TIN PLATED
 CURRENT RATING: 6A~7A AC,DC
 VOLTAGE RATING: 250V AC,DC
 APPLICABLE WIRE RANGE: AWG#22-24

RoHS Compliant		HSM 玄茂科技股份有限公司 HSUAN MAO TECHNOLOGY CO., LTD.	
APPD. 核准 DWG. 製圖 HELEN DATE 制表日 2012/2/9	TOLERANCE 容許公差 .0 ± .00 ± ANG. ± SCALE 比例 參考 UNIT 單位 MM PAGE 張數 1 OF 1	PART NAME 品名 4.2mm FEMALE TERMINAL BRASS MATERIAL TIN PLATING 22~24AWG ROHS	PART NO. 料號 T5150-TBH00000R

1 2 3 4 5 6 7 8