

RoHS Compliant		HSM 玄茂科技股份有限公司 HSUAN MAO TECHNOLOGY CO., LTD.	
APPD. 核准		TOLERANCE X ± - X.X ± 0.25 X.XX ± 0.13 X.XXX ± 0.05 ANGLES ± -	PART NAME 品名 TOP ENTRY P.C.B. JACK 6P6C BRACKET W / 4 HOLES BLACK COLOR ROHS
DWG. 製圖 Betty	SCALE 比例 參考	UNIT 單位 MM	PART NO. 料號 C0053-66CXB000R
DATE 制表日 2017/03/31	PAGE 張數 1 OF 2	SIZE 紙張尺寸 A 4	REV. 版次 A

MATERIALS:

- 1.CARRIER-PS (0.50mm THICK TAPE).
- 2.REEL-2mmTHICK PLASTIC WHEEL.
- 3.COVER TAPE-PE (0.045mm~0.12mm THICK TAPE).

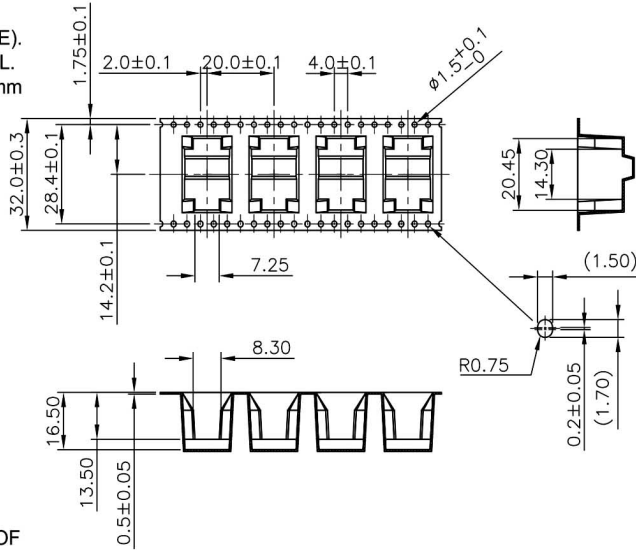

NOTES:

1. 10 EMPTY CAVITIES FOR BOTH OF TOP AND BOTTOM OF THE CARRIER.
2. 180 PCS PRODUCTS BE PACKAGED ON REEL.
3. 軸外保護帶 361-318.

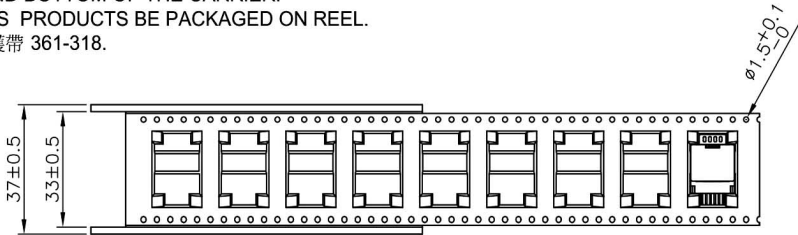

COVER TAPE
P/N: 361-059

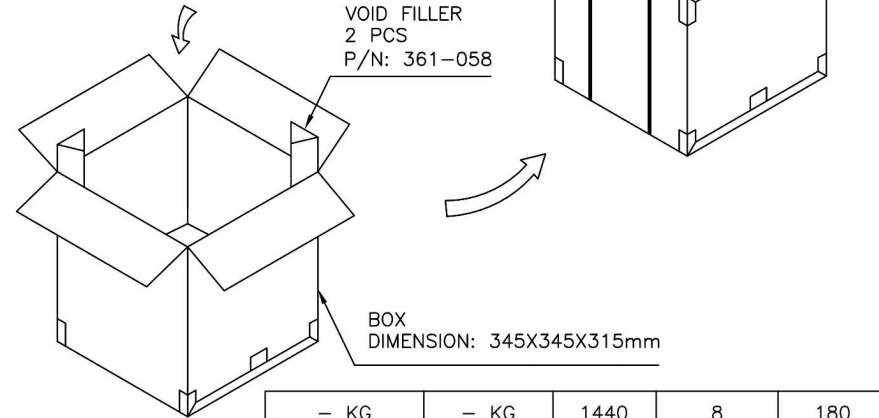
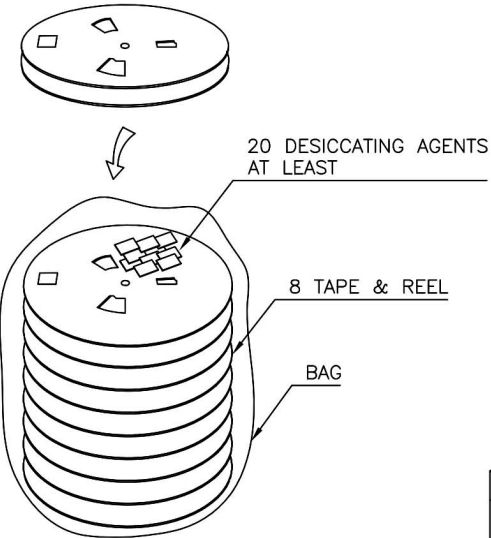
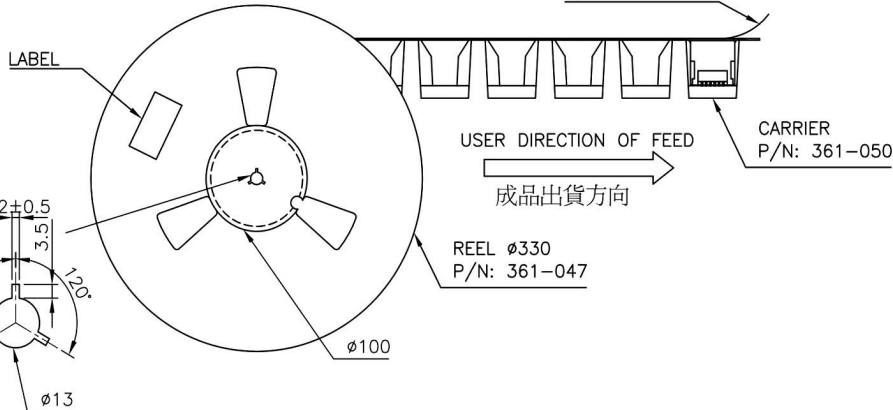

- KG	- KG	1440	8	180
GROSS WEIGHT (REF.)	NET WEIGHT (REF.)	PCS/BOX	REELS/BOX	PCS/REEL

RoHS Compliant		HSM 玄茂科技股份有限公司 HSUAN MAO TECHNOLOGY CO., LTD.	
APPD. 核准	SCALE 比例 參考	TOLERANCE	PART NAME 品名
DWG. 製圖 Betty	UNIT 單位 MM	SIZE. 紙張尺寸 A4	TOP ENTRY P.C.B. JACK 6P6C BRACKET W / 4 HOLES BLACK COLOR ROHS
DATE 制表日 2017/03/31	PAGE 張數 2 OF 2	REV. 版次 A	PART NO. 料號 C0053-66CXB000R