

1 2 3 4 5 6 7 8

A

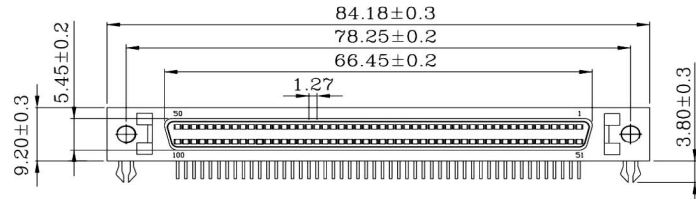

A: Metal Shell W/ Front Latch

B

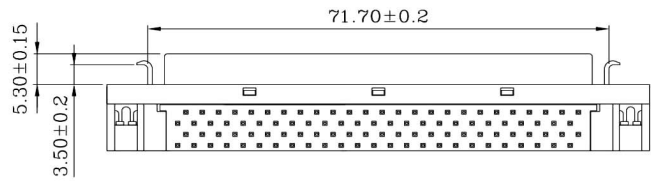

B: Metal Shell W/O Front Latch

D

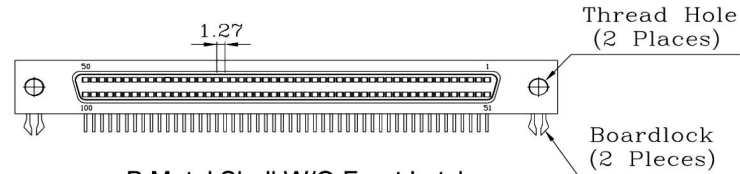

E

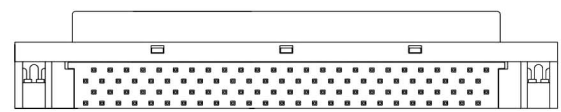

F

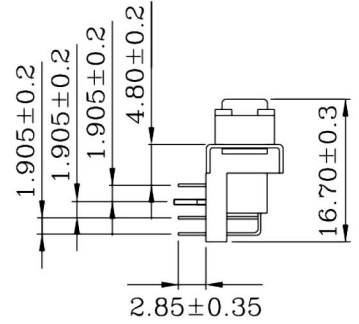

- **MATERIALS: (RoHS Compliant)**
 Housing And Cover: Plastic Thermoplastic P.B.T UL94V-0 Black
 Contacts: Phosphor Bronze Gold Selective Plated
 Front Shell: Steel Nickel Plated Over Copper
 Bracket: Steel Nickel Plated Over Copper
 Boardlock: Brass Tin Plated Over Copper

- **ELECTRICAL CHARACTERISTICS:**
 Contact Current Rating: 0.5 Amp
 Dielectric Withstanding Voltage: 500V AC
 Insulation Resistance: >500MΩ/Min
 Contact Resistance: 35mΩ/Max
 Operation Temperature: -55°C ~ +85°C

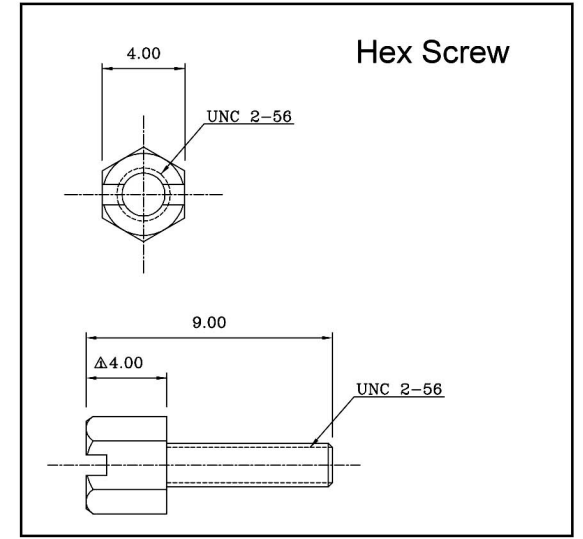

G

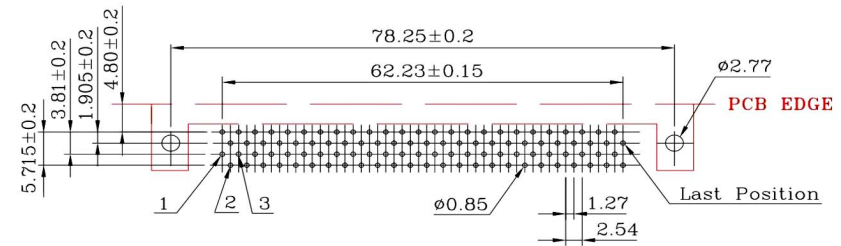

PCB Layout (B)

H

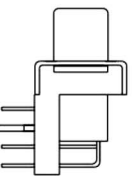

RoHS Compliant		玄茂科技股份有限公司 HSUAN MAO TECHNOLOGY CO., LTD.	
APPD. 核准 Betty	TOLERANCE 容許公差 .0 ± .00 ± ANG. ±	PART NAME 品名 SCSI-II D-SUB PCB RIGHT ANGLE TYPE 1.27mm 100P FEMALE THREAD INSERT 2-56UNC W/ FRONT LATCH W/ BOARDLOCK FIX 2PCS HEX SCREWS 4.0*9.0mm BLACK COLOR ROHS	
DWG. 製圖 Betty		SCALE 比例 參考	UNIT 單位 MM
DATE 制表日 2012/05/07	PAGE 張數 1 OF 1	SIZE 紙張尺寸 A4	REV. 版次 B
		PART NO. 料號 C0519-A0F(A,B)ZEXBR	

1 2 3 4 5 6 7 8