

**MATERIALS**

HOUSING: HI-TEMP PLASTIC (UL 94V-0)  
 SHELL: SPCC, NICKEL PLATING  
 TERMINAL: COPPER ALLOY, GOLD PLATED ON CONTACT AREA  
 TIN PLATING ON SOLDER TAIL

**SPECIFICATION**

CURRENT RATING: 1.5 AMP MAX  
 DIELECTRIC WITHSTANDING: 500V AC FOR ONE MINUTE  
 CONTACT RESISTANCE: 30m OHMS MAX  
 INSULATION RESISTANCE: 1000M OHMS MIN AT DC 500V  
 OPERATION TEMPERATURE: -30°C~+85°C

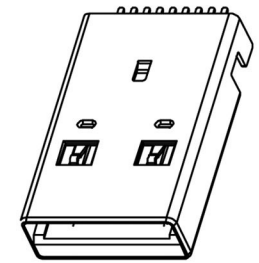
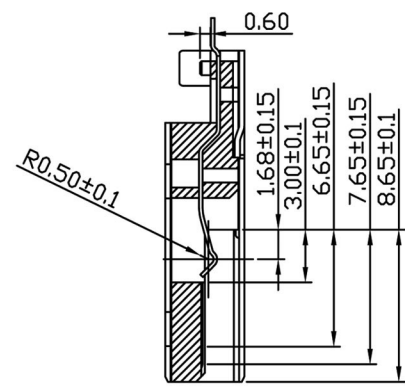

RECOMMENDED PCB LAYOUT

<b>RoHS</b> <b>Compliant</b>	<b>HSM</b> 玄茂科技股份有限公司 <b>HSUAN MAO TECHNOLOGY CO., LTD.</b>	
	PART NAME 品名 USB A TYPE 3.0 VERSION 9P MALE OFFSET H=1.9mm SMT TYPE SELECTIVE GOLD XXU" PLATING BLUE INSULATOR INSULATOR MATERIAL :LCP ROHS	
APPD. 核准		TOLERANCE LINEAR: .XX±0.20 .XXX±0.10 ANGLES: ±3°
DWG. 製圖 Helen	SCALE 比例 參考	SIZE. 紙張尺寸 A 4
DATE 制表日 2019/1/9	UNIT 單位 MM	REV. 版次 A
PAGE 張數 1 / 1	PART NO. 料號 C8342-09AMDL XLAR	